

## **Connections Between Work-Life Balance and Job Insecurity among Firefighters in Jakarta Indonesia**

Netania Emilisa\*  
Universitas Trisakti

Egabetha Amirah Yudhaputri  
Universitas Trisakti

Shafrani Dizar  
Universitas Trisakti

Ayu Tresna Ningsih  
Universitas Trisakti

Dietce Apriani  
Lincoln University Auckland

— *Review of* —  
**Integrative  
Business &  
Economics**  
— *Research* —

### **ABSTRACT**

This study aimed to analyze the effect of Work-Life Balance and Job Insecurity on Job Satisfaction and Affective Commitment among Firefighters in Jakarta. Data were collected from 105 samples with the data collection technique used was non-probability sampling with a purposive sampling method. In addition, validity and reliability tests were used as instrument tests, and Structural Equation Model (SEM) was used for hypothesis testing. The results of hypothesis testing in this study indicate that Work-Life Balance has a positive effect on Job Satisfaction, Job Insecurity has a negative effect on Job Satisfaction, Work-Life Balance has a positive effect on Affective Commitment, and Job Insecurity has a negative effect on Affective Commitment. The implication for managers is that they must think about the officers who work so that firefighters have a Work-Life Balance, must wear safer personal protective equipment to avoid the risk of accidents so as not to feel Job Insecurity, in the payroll system must be treated good so that firefighters feel Job Satisfaction, and to increase the Affective Commitment is expected to create a harmonious atmosphere in the work environment so that the loyalty of firefighters increases.

Keywords: Work-Life Balance, Job Insecurity, Job Satisfaction, Affective Commitment.

Received 18 July 2023 | Revised 16 February 2024 | Accepted 6 May 2024.

### **1. INTRODUCTION**

DKI Jakarta Province is the center of the government of the Republic of Indonesia. Its role as the capital makes DKI Jakarta a dense city, and every year, the population density in DKI Jakarta always increases. The dense population in the DKI Jakarta area has resulted in the emergence of problems that accompany DKI Jakarta. Pointing out that

population density brings many problems, such as traffic jams, limited habitable housing, crime, poor groundwater quality, subsidence of land levels, limited green space, and even floods and fires. Along with the risk of disasters that could occur in DKI Jakarta, the role of the fire brigade is essential for the capital city

Firefighters are not only trained to save victims from fires but also to save victims of traffic accidents, collapsed buildings, and other disasters. Along with the heavy workload of the fire brigade, organizations/agencies must make efforts to maintain the quality of human resources, one of which is by processing and utilizing existing resources, especially regarding employee job satisfaction and dissatisfaction. Several employees interviewed stated that there was an imbalance between their work and personal lives. Apart from that, several employees also expressed insecurity about their jobs. Honorary officers feel that the annual work contract system cannot guarantee continuity of work in the fire service.

Emilisa (2019) argues that there is still debate about how a manager develops organizational learning abilities efficiently within their organizations. Previous studies of organizational learning have demonstrated several leadership styles, such as supportive, transitional, transformational, spiritual, or authentic leadership leadership. This has triggered a positive effect on organizational learning (Peng et al., 2020). In developing Organizational Learning Capability leaders have their own way to overcome obstacles in organizational learning according to the style of leadership, such as examples provide direct motivation through interaction between employees so as to create a good working environment. This condition makes employees feel insecure (Agha et al., 2017); (Yudhaputri et al., 2021). Therefore, the company must try to help its employees integrate or balance their personal lives and their employees' work lives. This condition will certainly positively impact the company because a high level of satisfaction can increase the likelihood of employees feeling more engaged and committed to the company. So, a more stable work-life balance will increase employee job satisfaction.

Work-life balance influences employees' attitudes towards their organization and their lives. Work-life balance is essential when organizations must manage human resources professionally because high commitment and loyalty are required for organizational success. Firefighters need a work-life balance. With such routines and high levels of responsibility, firefighters perceive a significant imbalance in their work lives. Based on preliminary interviews conducted with several officers, the phenomenon was found that a low work-life balance made officers feel dissatisfied with their work. Apart from that, the officers put forward another factor that influences job satisfaction: job security, which arises from employees' interpretation of events, people, and signals related to the work and social environment. Job insecurity has been defined as employees' concerns about the survival of their jobs (Richter & Näswall, 2019). Work-life balance, an indicator of work satisfaction, makes it a good indicator of affective organizational commitment because when someone can harmonize their non-work life with their work life, it is possible to have a high level of commitment to their personal and company.

## **2. LITERATURE REVIEW**

### **2.1. Work-Life Balance**

Work-Life Balance is about finding the right balance between work and life, and about feeling comfortable with work and family commitments. Work-Life Balance is basically a balance between three components, namely paid work, unpaid work, and personal time

(Agha et al., 2017). Fayyazi & Aslani (2015) explain that Work-Life Balance is a balance between work and non-work life. Work-Life Balance is a balance between one's duties and obligations towards work and one's personal life (Takeuchi et al., 2018). Omar et al., (2020) also defines Work-Life Balance as life balance which refers to the balanced fulfillment of personal responsibilities (community roles, free time activities and family responsibilities) with work roles. Work-Life Balance practices enable employees to be effective in both work and personal roles. The more control an employee has over their life, the more able they are to balance work and family. Chandran & Abukhalifeh (2021) mention that work-life balance refers to the situation of juggling increasingly conflicting demands of work requirements that eat into the time a person has away from the job, to spend with friends and family, to pursue recreational pursuits, or even to sleep.

According to Lukmiati (2020), work-life balance has four dimensions, namely: (1). Work Interference Personal Life this dimension refers to the extent to which work interferes with personal life. For example, work can allow a person to manage time for his personal life; (2). Personal Life Interference Work, this dimension refers to how much a person's personal life interferes with life. For example, if an individual has problems in his personal life, this can interfere with the individual's work performance, (3). Work Personal Life Enhancement of Work, for example, if an individual is happy because his personal life is enjoyable, then this can make the individual's emotions work; and (4). Enhancement of Personal Life, this dimension refers to how work can improve an individual's personal quality of life. For example, the skills that individuals acquire in the workplace support individuals to utilize these skills in everyday life.

## **2.2. Job Insecurity**

Job Insecurity refers to employees' subjective perception of losing their jobs due to actual changes, rumored changes, or economic downturns (Cheung et al., 2019). Meanwhile Vo-Thanh et al., (2020) describe Job Insecurity as a situation that is felt to maintain the desired continuity in a threatened job situation. Job Insecurity arises from employees' interpretations of events, people, and signals related to the work and social environment. *Job Insecurity* has been defined as employees' concerns about the continuity of their employment (Richter & Näswall, 2019). Thus, Job Insecurity can be explained as an employee's overall concern about future work continuity (Stankevičiūtė et al., 2021). Obrenovic et al., (2021) also considers Job Insecurity as a subjective experience or perception. Because some employees can feel safe even when their jobs are threatened, or some feel unsafe when there is no threatening situation. Hsieh & Huang (2017) explains that Job Insecurity can be understood as the level of uncertainty an employee feels about the continuity of employment in the current position. This is a subjective perception resulting from evaluating the actual work environment. As a result, the same objective situation may result in different interpretations of uncertainty for different employees.

Cheung et al., (2019) stated that several factors cause Job Insecurity, including the following: the degree of threat an employee perceives regarding aspects of the job, such as the possibility of getting a promotion, maintaining the current wage level, or getting a pay increase. Individuals who value specific aspects of work (there is a possibility that these aspects will be lost) will be more anxious and feel helpless, the

meaning of the job to the individual. How vital this aspect of work is for an individual influences his or her level of insecurity, the threat level of the possibility of events that negatively affect the individual's overall work, for example, being fired or transferred to another branch office and the level of importance that an individual feels regarding the potential of each event. The sentence component in the Job Insecurity construct is the powerlessness felt by the individual.

### **2.3. Job Satisfaction**

Job Satisfaction is a combination of environmental style and psychological conditions that can make a person honestly admit satisfaction with the work done (Emilisa, 2006). Job Satisfaction is a positive feeling of happiness that comes from assessing one's job or work experience, and Job Satisfaction is determined by the level of effective adaptation to unpleasant circumstances (Emilisa et al., 2018). In other words, Job Satisfaction is an employee's attitude toward responsibility for the work they receive (Sihaloho & Indawati, 2021). *Job Satisfaction* is an extraordinary psychological state that arises from enjoying one's work experience. This can also be felt in workers' mindset towards their superiors, the work, social and physical environment, and the benefits they receive (Ahakwa et al., 2021). Biesok & Wyród-Wróbel (2017) also explained that Job Satisfaction is an employee's response to their work experience and emotional condition. Job Satisfaction creates intangible benefits, including reduced complaints and grievances, absenteeism, rotation, and layoffs. It is essential to understand the level of Job Satisfaction of employees because the level of Job Satisfaction achieved by employees will help frame strategies not only for increasing satisfaction levels but also for efficient privatization policy practices (Gopinath et al., 2020).

Causes of Job Satisfaction according to Syafrina (2018) are (1). Fulfillment, this model aims that satisfaction is determined by the extent to which job characteristics enable a person to meet his needs; (2). Discrepancy, this model aims that satisfaction is a result of fulfilled expectations. Met expectations indicate the difference between what a person expects from a job, such as a good salary and promotion opportunities, and what he or she receives; (3). Achievement of value, the idea underlying attainment values is that satisfaction results from the perception that a job enables the fulfillment of one's important job values; (4). Justice, in this model, satisfaction is a function of how individuals are treated fairly in the workplace.

### **2.4. Affective Organizational Commitment**

Affective Organizational Commitment is categorized as one of the three types of organizational commitment, and it is defined as an employee's desire to stay with the organization on an emotional level, by identifying with the organization's goals and being satisfied with his or her job and as the degree to which an employee identified with the organization's goals (Pham et al., 2023). Affective Commitment describes individuals' emotional identification, involvement, and attachment toward their organization. This is related to a person's desire to contribute to the welfare of the organization and the willingness to affiliate and identify with oneself (El Badawy et al.,

2018). Thus, when employees are effectively committed to them, they are more likely to stay with them because they want to, whereas other employees develop other forms of commitment to their organizations, as well as normative commitment and continuance commitment (Bouraoui et al., 2019).

Every organization needs employees who consider their organizational duties as personal responsibility to achieve goals. Achieving goals is a function of the positive attitude of the workforce. Therefore, an organization must focus on employees seeking to recognize, classify, and internalize organizational practices to achieve organizational performance and engage in unique ideas, concepts, beliefs, and designs (Kaur et al., 2020).

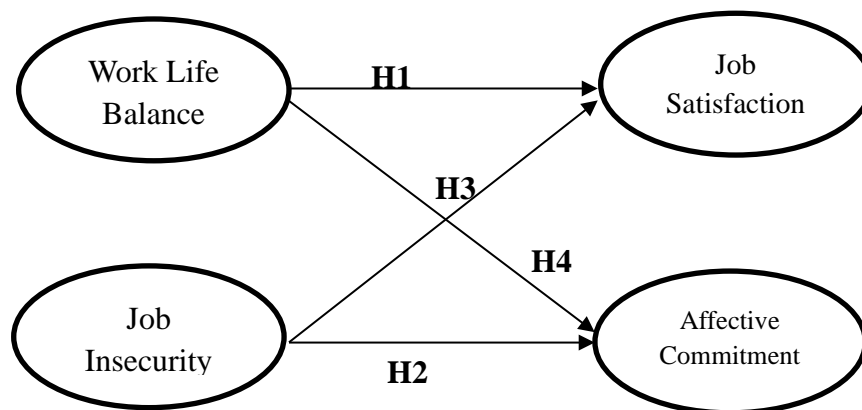

**Figure 1: Conceptual Framework**

### 3. HYPOTHESES DEVELOPMENT

The more stable the Work-Life Balance, the greater the Job Satisfaction, as in the study of Fayyazi & Aslani (2015) which proves that Work-Life Balance has a positive effect on Job Satisfaction. Aulia & Emilisa (2022) also proves that Work-Life Balance has a positive effect on Job Satisfaction. Based on several previous studies above, the researcher proposed the following hypothesis:

H1: Work-Life Balance has a positive effect on Job Satisfaction

Job Insecurity is a crucial aspect of influencing Job Satisfaction. The higher the level of Job Insecurity, the lower employee job satisfaction will be (Zheng et al., 2014), Job Insecurity has a negative influence on Job Satisfaction. Research conducted by Riana et al., (2020) also proves that Job Insecurity has a negative effect Job Satisfaction. Based on several previous studies above, the researcher proposed the following hypothesis:

H2: Job Insecurity has a negative effect on Job Satisfaction

Work-Life Balance practices enable employees to be effective in both work and personal roles. The more control employees have over their lives, the more they can balance work and family. Research from Berk & Gundogmus (2018) proves that Work-Life Balance positively affects Organizational Commitment. Apart from that Shabir & Gani (2020) also proves that Work-Life Balance positively affects Organizational Commitment.

Based on several previous studies above, the researcher proposed the following hypothesis:

H3: Work-Life Balance has a positive effect on Affective Organizational Commitment  
Job Insecurity is a factor that can influence Organizational Commitment. This statement is supported by research conducted by Stankevičiūtė et al., (2021), which proves that Job Insecurity affects Organizational Commitment. (Lumingkewas et al., 2019) Also proves that Job Insecurity has a significant negative effect on Organizational Commitment. Based on several previous studies above, the researcher proposed the following hypothesis:

H4: Job Insecurity has a negative effect on Affective Organizational Commitment.

#### 4. VARIABLES AND MEASUREMENT

According to Hasan et al., (2021), statements for the Work-Life Balance variable consist of 5 statement items with examples as follows: My personal life has become miserable because of this job. This job has made my personal life difficult. Job Insecurity is measured using statement items taken from Stankevičiūtė et al., (2021), consisting of 4 statement items: I feel insecure about the future of my job, I am not sure I can keep my job. Statements for Job Satisfaction adapted from Irawanto et al., (2021) consist of 5 items: I am satisfied with my current job and my colleagues. The final variable is Affective Organizational Commitment, which was adapted from (Hasan et al., 2021) using 7 question items as follows I would love to spend the rest of my career with this organization; I do not think I can be easily tied to another organization like this one. All variables using the five likert scale, from 1 = strongly disagree, to 5 = strongly agree.

#### 5. SAMPLE

The questionnaires were distributed to Fire Officers of the Jakarta Administrative City Fire Handling and Rescue Department., as the research sample using purposive sampling. If the population is unknown, according to Hair et al., (2018) recommend the minimum sample size is 5 times the number of question items contained in the questionnaire. The total question in this study is 21 so that the minimum sample size of the study is minimum sample = number of indicators X 5 = 21 X 5 = 105.

#### 6. INSTRUMENT TEST

In the test results validity of all items statement has a value greater than 0.55, so the statement is valid or in other words can be used in this study.

Tabel 1: Validity Test

Item	Factor Loading	Decision
<i>Work-Life Balance</i>		
My personal life has become difficult because of this job	0.836	Valid

Item	Factor Loading	Decision
This job makes my personal life difficult	0.853	Valid
I often put off personal life matters for the sake of this job	0.878	Valid
Personal life drains my energy for work	0.825	Valid
My performance was poor because of my personal life	0.884	Valid
<i>Job Insecurity</i>		
I feel insecure about my future work	0.950	Valid
I am not sure I can keep my job	0.909	Valid
Maybe I will lose my job soon	0.807	Valid
I may lose my job shortly	0.848	Valid
<i>Job Satisfaction</i>		
I am satisfied with my current job	0.831	Valid
I am satisfied with my current coworkers	0.786	Valid
I am satisfied and happy with my current boss	0.756	Valid
I am satisfied with my current salary	0.786	Valid
Overall, I am satisfied with this job	0.878	Valid
<i>Affective Organizational Commitment</i>		
I love to spend the rest of my career with this organization	0.763	Valid
I feel as if this organizational problem is my problem	0.749	Valid
I cannot be as easily attached to another organization as to this one	0.796	Valid
I feel like part of the family in my organization	0.840	Valid
I feel emotionally attached to this organization	0.654	Valid
This organization has much personal meaning for me	0.900	Valid
I feel a strong sense of belonging to my organization	0.851	Valid

Source: SPSS

And for reliability test the cronbach alpha coefficients for Work-life Balance, Job Insecurity, Job Satisfaction and Affective Organizational Commitment variables meet the current recommended reliability criteria greater than 0.60.

Table 2: Reliability Test

Variable	Items	N	Cronbach Alpha	Decision
Work-life Balance	5	105	0.904	Reliable
Job Insecurity	4	105	0.720	Reliable
Job Satisfaction	5	105	0.891	Reliable
Affective Organizational Commitment	7	105	0.908	Reliable

Source: SPSS

## 7. DEMOGRAPHIC CHARACTERISTICS

All respondents are male (100%), age range between 20 – 25 years old (42.9%), education high school (55.2%) degree and tenure 1-5 years (45.7%).

Table 3: Demographic Characteristics

Demographic	Frequency	Percentage
<b>Gender:</b>		
Male	105	100
Female	0	0
<b>Age:</b>		
20 – 25 years old	45	42.9
26 - 30 years old	26	24.8
31 – 50 years old	34	32.4
<b>Education:</b>		
Highschool	58	55.2
Diploma	39	37.1
Undergraduate	8	7.7
<b>Tenure:</b>		
< 1 year	20	19.0
1-5 year	48	45.7
6-10 year	25	23.8
11-15 year	12	11.5

Source: SPSS

## 8. DATA ANALYSIS METHOD

Data have been collected processed by using Structural Equation Modeling (SEM). This method used with the consideration relationships between variables that occur simultaneously. SEM is precisely used to change one dependent to independent variable for the next relations. SEM is a similar method to a combination data processing, using *factor analysis and multiple regression analysis*. Further, SEM reflect together regression analysis impact on significant.

Table 4: Goodness of Fit Model

Measurement Types	Goodness of Fit Index	Result	Cut-Off	Conclusion
Absolute Fit Measure	Chi-Square	659,448	Expected to be small	<i>Poor Fit</i>
	p-value	,000	$\geq 0,05$	<i>Poor Fit</i>
	RMSEA	,157	$\leq 0,10$	<i>Poor Fit</i>
Incremental	NFI	,911	$\geq 0,90$	<i>Goodness of Fit</i>



Fit Measure	TLI	,900	$\geq 0,90$	<i>Goodness of Fit</i>
	CFI	,926	$\geq 0,90$	<i>Goodness of Fit</i>
Parsimonius Fit Measures	CMIN/DF	3,565	Lower Limit 1, upper limit 5	<i>Goodness of Fit</i>

Source: AMOS

The Goodness of fit test results, which show the poor fit conclusion, are Chi-square with a cut-off value  $< 2$  with a value of 659.448, then p-value with a cut-off  $> 0.05$  with a result of 0.000, RMSEA with a cut-off  $< 0.10$  and the result is 0.157. Furthermore, the Goodness of Fit test results show that the conclusion of Goodness of Fit is NFI with a cut off  $> 0.90$  and the result is 0.911, TLI with a cut off  $> 0.90$  and the result is 0.900, CFI with a cut off  $> 0.90$  and the result is 0.926, CMIN/DF where the lower cut off limit is one and the upper limit is 5 with a result of 3.565 which means Goodness of Fit. From the Goodness of Fit test, it can be concluded that the model above is feasible because several items reach the Goodness of Fit criteria. In a model, the minimum Goodness of Fit is one. A model that has passed the Goodness of Fit test can be used for the next test, which is a hypothesis test.

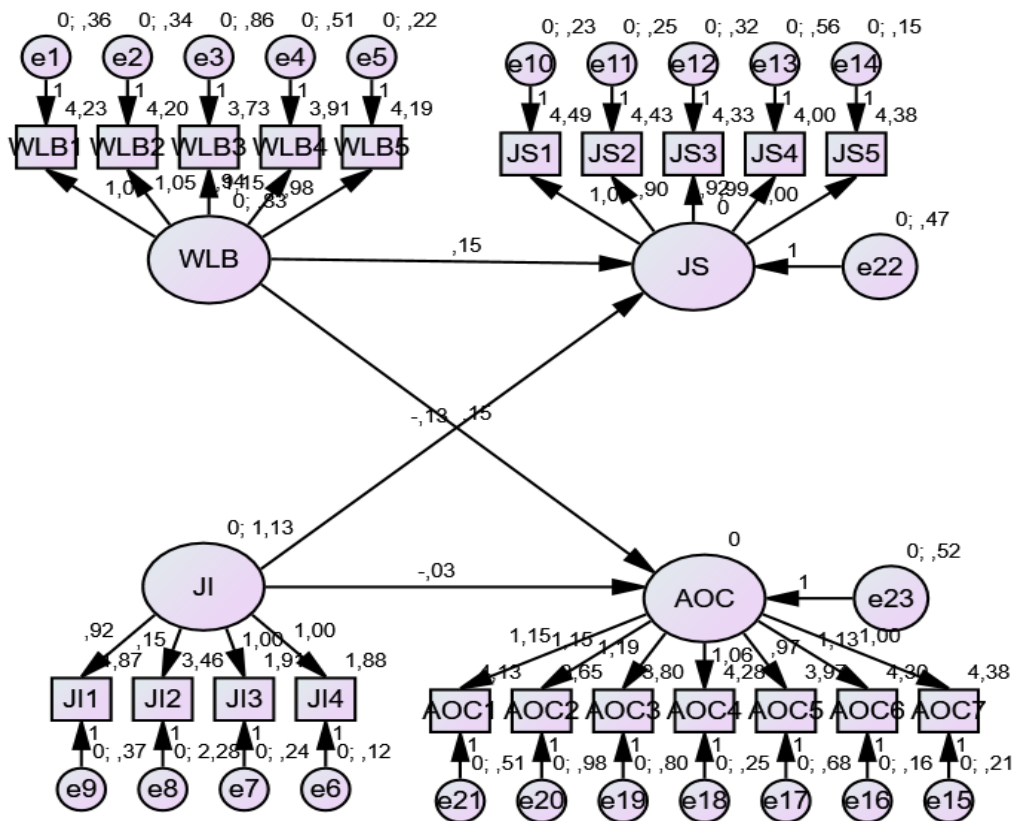

Figure 2: Structural Equation Model

## 9. DESCRIPTIVE STATISTICS

The average value for the Work-Life Balance variable is 4.0533 because firefighters from the West Jakarta City Administration Fire and Rescue Department can balance their work and personal lives, are always committed to work, and know their responsibilities with other activities outside their work. The average value of the Job Insecurity variable is 2.2786, which shows that firefighters do not feel job insecurity in their work environment and can even build relationships with other firefighters. The officers do not feel any job insecurity even though their job as a firefighter is full of significant risks, including risking their lives when carrying out their work. The firefighters carry out their work according to the motto: never go home before the fire goes out. The average value of the Job Satisfaction variable is 4.3257, showing that firefighters are satisfied with their work while working. The sense of satisfaction with their work from the firefighters of the West Jakarta City Administration Fire and Rescue Sub-department can be described by several factors, namely compensation, supervision, the work itself, relationships with co-workers, working conditions, and a sense of satisfaction if successful when extinguishing a fire that happened. The average value of the Affective Organizational Commitment variable is 4.0721, and it shows that the firefighters are loyal and have a commitment not to leave the firefighters of the Jakarta Administration City Fire and Rescue Service; the officers have a strong feeling for their organization.

## 10. HYPOTHESES TESTING RESULTS AND DISCUSSION

The results showed that of the four hypotheses (table 5), it turns out all hypotheses are supported.

Table 5: Testing Hypothesis Result

Hypothesis	Estimation	$\rho$ - value	Decision
H1: Work-Life Balance has a positive effect on Job Satisfaction	0.148	0.003	H <sub>1</sub> supported
H2: Job Insecurity has a negative effect on Job Satisfaction	-0.125	0.003	H <sub>2</sub> supported
H3: Work-Life Balance has a positive effect on Affective Organizational Commitment	0.151	0.006	H <sub>3</sub> supported
H4: Job Insecurity has a negative effect on Affective Organizational Commitment	-0.034	0.001	H <sub>4</sub> supported

Source: SPSS

The table above shows a significance value of 0.003 < 0.05 with an estimated value ( $\beta$ ) of 0.148, so it can be concluded that there is a positive influence between Work-Life Balance and Job Satisfaction.. Based on previous research, it was said by (Sihaloho & Indawati, 2021) that the results showed that Work-Life Balance influenced Job Satisfaction. Another similar study also showed that Work-Life Balance significantly

positively influenced Job Satisfaction. Research results from Saeed & Farooqi (2014) show that the practice of Work-Life Balance and the level of Job Satisfaction have a positive relationship. This can also be related to the average value of the Work-Life Balance variable, namely, personal life drains my energy for work, and the Job Satisfaction variable, namely, I am satisfied with my current salary. It means that even though working as a firefighter is very draining of energy and energy, it is comparable to the salary received, so firefighters feel satisfied with their work.

The results of this study show that Job Insecurity has a negative effect on Job Satisfaction. According to (Brahmannanda & Dewi, 2020), previous research found that Job Insecurity had a negative and significant effect on Job Satisfaction. This means that Job Insecurity can cause low Job Satisfaction. According to (Riana et al., 2020), Job Insecurity has a negative effect on Job Satisfaction.

This can also be related to the statement in the Job Insecurity variable, namely, maybe I will soon lose my job. This is because if something undesirable happens while on duty, namely when extinguishing a fire during a large fire and an accident occurs, it endangers or disables the firefighter. This will make the firefighter unable to serve as a firefighter and will likely be dismissed so that the officer who experienced the accident will not achieve Job Satisfaction.

The results of this study show that Work-Life Balance has a positive effect on Affective Organizational Commitment. This is supported by previous research. According to (Kim, 2014), Work-Life Balance positively affects employees' Affective Organizational Commitment to their organization. Then Emilisa (2019) and Sasongko (2015) research said that Work-Life Balance has an insignificant influence on Affective Organizational Commitment or that Work-Life Balance weakly influences Affective Organizational Commitment. This can also be related to the statement in the Work-Life Balance variable: I often postpone personal life problems for the sake of this job and the Affective Organizational Commitment variable, namely, I feel as if this organizational problem is my problem, which means firefighters often postponing personal problems in order to carry out their duties and responsibilities if they are extinguishing a fire when a fire occurs because firefighters consider the problem of extinguishing a fire when a fire occurs as if it were their problem.

The results of this study show that Job Insecurity has a negative effect on Affective Organizational Commitment. These results are supported by previous research, namely by McGinley et al., (2020), that Job Insecurity has a negative impact on Affective Organizational Commitment. Affective Organizational Commitment indicates an employee's personal and spontaneous desire to work for the benefit of their organization. Job insecurity causes negative emotions, such as anxiety, depression, and irritation. (Kocak et al., 2018) found that Job Insecurity negatively and significantly affects Affective Organizational Commitment. An increase in the perception of Job Insecurity of a working firefighter has a negative and significant effect on Affective

Organizational Commitment. This can be related to the statement in the mean Job Insecurity. Namely, I feel insecure about the future of my job, and according to the statement in the Affective Organizational Commitment variable, I will be thrilled to spend the rest of my career with this organization. This concerns the safety of the soul and body of firefighters in the work they are currently doing, which means that fire firefighters think about the risks of continuing to work, so they reconsider spending their career in the Jakarta City Administration Fire and Rescue Sub-dept.

## 11. CONCLUSION AND MANAGERIAL IMPLICATION

In this research, officers from the Jakarta City Administration Fire and Rescue Sub-dept. have a good Work-Life Balance, meaning that even though firefighters feel there are obstacles both at work and personally that interfere with their concentration at work, they can still complete their work well. Compact so that firefighters do not feel job insecurity when carrying out their work, thus giving rise to Job Satisfaction in firefighters, which makes firefighters have an Affective Organizational Commitment.

The Jakarta City Administration Fire and Rescue Department must provide more security in carrying out their duties; firefighters must wear personal protective equipment as needed at the scene to avoid the risk of accidents or health problems so that firefighters do not experience job insecurity. The salary system must be improved, meaning that salaries are paid according to a firefighter's skills, abilities, and work.

## REFERENCES

- [1] Agha, K., Azmi, F. T., & Irfan, A. (2017). Agha, K., Azmi, F. T., & Irfan, A. (2017). Work-Life Balance and Job Satisfaction: An Empirical study Focusing on Higher Education Teachers in Oman. *International Journal of Social Science and Humanity*, 7(3), 164–171. <https://doi.org/10.18178/ijssh.2017.v.7.3.813>
- [2] Ahakwa, I., Yang, J., Agba Tackie, E., & Atingabili, S. (2021). The Influence of Employee Engagement, Work Environment and Job Satisfaction on Organizational Commitment and Performance of Employees: A Sampling Weights in PLS path Modelling. *SEISENSE Journal of Management*, 4(3), 34–62. <https://doi.org/10.33215/sjom.v4i3.641>
- [3] Aulia, S. H., & Emilisa, N. (2022). *Pengaruh Organizational Resilience, Work Life Balance, Intrinsic Reward Terhadap Job Satisfaction Pada Karyawan De JAVA Hotel Bandung*. 7(1), 22–33. <https://doi.org/https://doi.org/10.37531/yum.v5i3.1963>
- [4] Berk, C., & Gundogmus, F. (2018). The Effect of Work-Life Balance on Organizational Commitment of Accountants. *Management*, 131(1990), 137–159. <https://doi.org/10.26493/1854-4231.13.137-159>
- [5] Biesok, G., & Wyród-Wróbel, J. (2017). Job Satisfaction and Its Influence on Proactive Behaviour. *European Journal of Business Science and Technology*, 3(1), 44–53. <https://doi.org/10.11118/ejobsat.v3i1.81>
- [6] Bouraoui, K., Bensemmane, S., Ohana, M., & Russo, M. (2019). Corporate social responsibility and employees' affective commitment: A multiple mediation model.

- Management Decision*, 57(1), 152–167. <https://doi.org/10.1108/MD-10-2017-1015>
- [7] Brahmanna, S., & Dewi, I. G. A. M. D. (2020). Work Insecurity and Compensation on Turnover Intention Mediated by The Job Satisfaction of Employees. *International Research Journal of Management, IT & Social Sciences*, 7(5), 89–98.
- [8] Chandran, K. S., & Abukhalifeh, A. N. (2021). Systematic Literature Review of Research on Work-Life Balance in Hospitality Industry since Millennium. *Review of Integrative Business and Economics Research*, 10(1), 14–33.
- [9] Cheung, F. Y. L., Wu, A. M. S., & Ching Chi (Cindia), L. (2019). Effect of job insecurity, anxiety and personal resources on job satisfaction among casino employees in macau: a moderated mediation analysis. *Journal of Hospitality Marketing and Management*, 28(3), 379–396. <https://doi.org/10.1080/19368623.2019.1525332>
- [10] El Badawy, T. A., Chinta, R., & Magdy, M. M. (2018). Does ‘gender’ mediate or moderate the relationship between ‘quality of work life’ and ‘organizational commitment’?: Evidence from SMEs in Egypt. *Gender in Management*, 33(4), 332–348. <https://doi.org/10.1108/GM-04-2017-0050>
- [11] Emilisa, N. (2006). Pengaruh Gaya Kepemimpinan Terhadap Kepuasan Kerja Karyawan. *Media Riset Bisnis & Manajemen*, 6(3), 285–301.
- [12] Emilisa, N. (2019). The Role of Altruism, Organizational Learning Capability and Organizational Trust: A Study from Online Motorcycle Drivers in Jakarta. *Review of Integrative Business and Economics Research*.
- [13] Emilisa, N., Putra, D. P., Yudhaputri, E. A., & Trisakti, U. (2018). Perceived External Prestige , Deviant Workplace Behavior Dan. *Jurnal Manajemen Dan Pemasaran Jasa*, 11(2), 247–262.
- [14] Fayyazi, M., & Aslani, F. (2015). The Impact of Work-Life Balance on Employees’ Job Satisfaction and Turnover Intention; the Moderating Role of Continuance Commitment. *International Letters of Social and Humanistic Sciences*, 51, 33–41. <https://doi.org/10.18052/www.scipress.com/ilshs.51.33>
- [15] Gopinath, R., Ramamoorthy, R., & Kalpana, R. (2020). Impact of Emotional Intelligence and Organizational Commitment: Testing the Mediator Role of Job Satisfaction. *International Journal of Management (IJM)*, 11(11), 2883–2893.
- [16] Hair, J. F., Anderson, R. E., Tatham, R. L., & Black, W. C. (2018). Multivariate Data Analysis, Multivariate Data Analysis. In *Multivariate Data Analysis, Multivariate Data Analysis B2 - Multivariate Data Analysis, Multivariate Data Analysis* (Vol. 87, Issue 4).
- [17] Hasan, T., Jawaad, M., & Butt, I. (2021). *The Influence of Person – Job Fit , Work – Life Balance , and Work Conditions on Organizational Commitment : Investigating the Mediation of Job Satisfaction in the Private Sector of the Emerging Market.*
- [18] Hsieh, H. H., & Huang, J. T. (2017). Core Self-Evaluations and Job and Life Satisfaction: The Mediating and Moderated Mediating Role of Job Insecurity. *Journal of Psychology: Interdisciplinary and Applied*, 151(3), 282–298. <https://doi.org/10.1080/00223980.2016.1270888>
- [19] Irawanto, D. W., Novianti, K. R., & Roz, K. (2021). Work from home: Measuring satisfaction between work–life balance and work stress during the covid-19 pandemic in indonesia. *Economies*, 9(3). <https://doi.org/10.3390/economies9030096>
- [20] Kaur, P., Malhotra, K., & Sharma, S. K. (2020). Moderation-mediation framework connecting internal branding, affective commitment, employee engagement and job satisfaction: an empirical study of BPO employees in Indian context. *Asia-Pacific Journal of Business Administration*, 12(3–4), 327–348.

- <https://doi.org/10.1108/APJBA-10-2019-0217>
- [21] Kim, H. K. (2014). Work-Life Balance and Employees' Performance: The Mediating Role of Affective Commitment. *An International Journal*, 6(1), 37–51.
- [22] Kocak, D., Ozdemir, S., & Kerse, G. (2018). Does The Perception of Job Insecurity Bring Emotional Exhaustion The Relationship between Job Insecurity, Affective Commitment and Emotional Exhaustion. *Business and Economics Research Journal*, 9(3), 651–663. <https://doi.org/10.20409/berj.2018.129>
- [23] Lukmiati, 2020. (2020). Pengaruh Work Life Balance terhadap Kinerja Karyawan pada Karyawan Staff PT. Muara Tunggal. *Jurnal Ekobis Dewantara*, 3(3), 46–50. [https://doi.org/10.26460/ed\\_en.v3i3.1688](https://doi.org/10.26460/ed_en.v3i3.1688)
- [24] Lumingkewas, C. A., Norman, U., Roharjo, K., & Itami, H. (2019). Effect of Job Insecurity to Organizational Commitment and Intention to Leave. *Wacana: Jurnal Sosial Dan Humaniora*, 22(4), 256–260.
- [25] McGinley, S., Line, N. D., Wei, W., & Peyton, T. (2020). Studying the effects of future-oriented factors and turnover when threatened. *International Journal of Contemporary Hospitality Management*, 32(8), 2737–2755. <https://doi.org/10.1108/IJCHM-12-2019-1002>
- [26] Obrenovic, B., Du, J., Godinic, D., Baslom, M. M. M., & Tsoy, D. (2021). The Threat of COVID-19 and Job Insecurity Impact on Depression and Anxiety: An Empirical Study in the USA. *Frontiers in Psychology*, 12(August), 1–15. <https://doi.org/10.3389/fpsyg.2021.648572>
- [27] Omar, M. K., Aluwi, A. H., Fauzi, M. W. M., & Hairpuddin, N. F. (2020). Work stress, workload, work-life balance, and intention to leave among employees of an insurance company in Malaysia. *International Journal of Business, Economics and Law*, 21(2), 70–78. [http://ijbel.com/wp-content/uploads/2020/08/IJBEL21\\_061.pdf](http://ijbel.com/wp-content/uploads/2020/08/IJBEL21_061.pdf)
- [28] Peng, L., Lei, S., Guo, Y., & Qiu, F. (2020). How can leader humor enhance subordinates' service creativity? The moderator of subordinates' SFIT and the mediator of role modeling. *Leadership and Organization Development Journal*, 41(6), 865–882. <https://doi.org/10.1108/LODJ-03-2020-0087>
- [29] Pham, T. T. P., Truong, G. Q., Van Nguyen, T., & Nguyen, P. V. (2023). The Meaning of Public Service Motivation: Human Resource Management Practices in the Public Sector. *Review of Integrative Business and Economics Research*, 12(2), 1–27.
- [30] Riana, I. G., Minarsari, M., & Piartini, P. S. (2020). Implikasi Job Insecurity Terhadap Kepuasan Kerja Dan Intention To Leaven To Leave. *EKUITAS (Jurnal Ekonomi Dan Keuangan)*, 3(2), 206–225. <https://doi.org/10.24034/j25485024.y2019.v3.i2.4069>
- [31] Richter, A., & Näswall, K. (2019). Job insecurity and trust: Uncovering a mechanism linking job insecurity to well-being. *Work and Stress*, 33(1), 22–40. <https://doi.org/10.1080/02678373.2018.1461709>
- [32] Saeed, K., & Farooqi, Y. A. (2014). Examining the Relationship between Work Life Balance, Job Stress and Job Satisfaction Among University Teachers. *International Journal of Multidisciplinary Sciences and Engineering*, 5(6), 9–15.
- [33] Shabir, S., & Gani, A. (2020). Impact of work–life balance on organizational commitment of women health-care workers: Structural modeling approach. *International Journal of Organizational Analysis*, 28(4), 917–939. <https://doi.org/10.1108/IJOA-07-2019-1820>
- [34] Sihalo, C. N., & Indawati, N. (2021). Peran Mediasi Emotional Exhaustion pada Pengaruh Work Life Balance terhadap Kepuasan Kerja Karyawan Wanita di Universitas Negeri Surabaya. *Jurnal Ilmu Manajemen*, 9(1), 228.

- <https://doi.org/10.26740/jim.v9n1.p228-240>
- [35] Stankevičiūtė, Ž., Staniškienė, E., & Ramanauskaitė, J. (2021). The impact of job insecurity on employee happiness at work: A case of robotised production line operators in furniture industry in Lithuania. *Sustainability (Switzerland)*, 13(3), 1–20. <https://doi.org/10.3390/su13031563>
- [36] Syafrina, N. (2018). Faktor-Faktor Yang Mempengaruhi Kepuasan Kerja Karyawan Pada Pt. Aspacindo Kedaton Motor Kandis Kabupaten Siak. *Jurnal Benefita*, 3(3), 455. <https://doi.org/10.22216/jbe.v3i3.3004>
- [37] Takeuchi, M., Nomura, K., Horie, S., Okinaga, H., Perumalswami, C. R., & Jagsi, R. (2018). Direct and indirect harassment experiences and burnout among academic faculty in Japan. *Tohoku Journal of Experimental Medicine*, 245(1), 37–44. <https://doi.org/10.1620/tjem.245.37>
- [38] Vo-Thanh, T., Vu, T. Van, Nguyen, N. P., Nguyen, D. Van, Zaman, M., & Chi, H. (2020). How does hotel employees' satisfaction with the organization's COVID-19 responses affect job insecurity and job performance? *Journal of Sustainable Tourism*, 29(6), 907–925. <https://doi.org/10.1080/09669582.2020.1850750>
- [39] Yudhaputri, E. A. E., & Netania; Lunarindiah, G. (2021). Differences between Generation X and Generation Y in Job Involvement and Commitment : A Study in Event Organizer Companies. *Review of Integrative Business & Economics*, 10(3), 146–159.
- [40] Zheng, X., Diaz, I., Tang, N., & Tang, K. (2014). Job insecurity and job satisfaction: The interactively moderating effects of optimism and person-supervisor deep-level similarity. *Career Development International*, 19(4), 426–446. <https://doi.org/10.1108/CDI-10-2013-0121>